

# Glass, Holders & Electrodes

## Glass Capillaries

- Fire-Polished Single-Barrel Standard-wall and Thin-wall glass Tubing** ..... 118  
WPI's Fire-polished glass capillaries are perfect for recording electrodes. The fire-polished ends eliminate possible damage to the chloridized (Ag/AgCl) wire and microelectrode holder, and also facilitate smoother insertion into a microelectrode holder.
- Single-Barrel Standard Wall Capillaries (with or without inner filament)** ..... 118  
WPI's standard wall capillaries are easier to pull longer and smaller tip micropipettes. These are particularly suitable for intracellular microelectrodes. The inner filament greatly facilitates pipette filling with electrolyte.
- Single-Barrel Thin Wall Capillaries (with or without inner filament)** ..... 118  
Thin wall capillaries produce smaller OD and bigger ID pipettes that are suitable for microinjection

## Patch Clamp Glass Capillaries

- Best for patch clamp studies** ..... 119

## Multi-Barrel Glass Capillaries

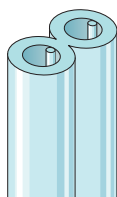

- Multi-Barrel Standard wall tubing (with inner filament)** ..... 120  
Designed for microiontophoresis
- Septum Theta Capillaries** ..... 120  
Ideal for making dual-channel micropipettes used for intracellular work in small cells
- Piggyback Glass Capillaries (with filament)** ..... 120  
Ideal for making two-barrel electrodes with a significant tip diameter differential
- Borosilicate Glass Rod** ..... 120  
Suitable for making rod pipettes to be used as tools to dissect chromosomes or to probe and move objects
- Five- and Seven-Barrel Micropipette Blanks** ..... 121  
Designed for precise local application of chemicals in extracellular electrophysiological studies

## μTip Pre-Pulled Glass Capillaries

- Borosilicate Glass Micropipettes** ..... 122  
Plain, luer and silanized μTips



## Microfil, Micropipette Holders and Accessories

- MicroFil Nonmetallic Syringe Needles** ..... 123  
For filling micropipettes
- Micropipette Storage Jar** ..... 121  
For 1.0mm, 1.2mm, 1.5mm and 2.0mm OD glass pipettes
- PolyFil Multi-Barrel Micropipettes Coupling Kit** ..... 123  
For easy and secure coupling of a multi-barrel micropipette to a pressure source
- Micropipette Holders & Half-Cells** ..... 124  
For coupling fluid-filled glass micropipettes to high input impedance amplifiers
- Optical Quality Glass Bottom Sterile Cell Culture Dishes** ..... 173  
For microinjection, fluorescence, high resolution image analysis, cell culture, electrophysiology

## Microelectrodes

- Metal Microelectrodes** For extracellular recording ..... 100
- Dri-Ref™ Reference Electrodes** featuring extremely low electrolyte leakage ..... 79
- CALBUF** Calcium Calibration Solutions ..... 79
- BetterSkin™ Electrodes** Reusable surface-mounted electrodes ..... 128
- Disposable Ag/AgCl Snap Electrodes** ..... 128
- GEL100** Conductive Electrode Gel ..... 128
- Ag/AgCl Half-Cells** ..... 129



# Glass Capillaries

Clean, high quality glass for making micropipette electrodes and other research implements

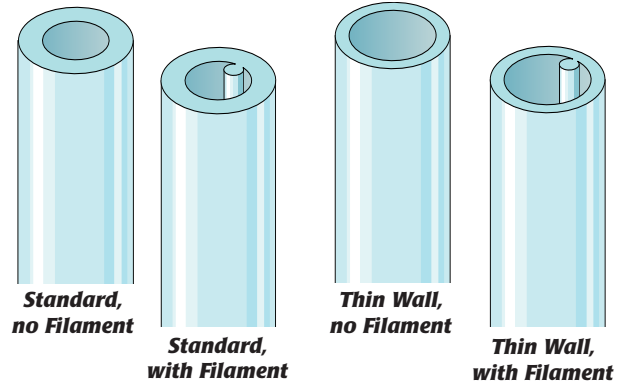

WPI offers a wide spectrum of high-quality glass capillaries. We take pride in our ability to ship your glass order within 48 hours. If you need a special glass that does not appear in our catalog, please call us. We will make every effort to provide it for you.

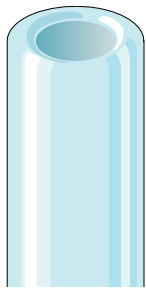

**Fire-Polished** glass capillaries are easier to insert into microelectrode holders without damaging the gasket. More importantly, fire-polished glass won't scratch the chloridized wire used in a recording electrode. Fire-polishing does not affect the glass's mechanical or electrical properties.

**Borosilicate glass capillaries:** Close dimensional tolerances assure microelectrode uniformity and reproducibility. Available in one-, two-, three-, five- and seven-barrel configurations; a complete range of single barrel thin-wall sizes; and a variety of special configurations. Capillaries with filaments contain a solid filament fused to the inner wall, which speeds filling of electrodes. Capillaries with or without inner filaments are available for making microelectrodes in a wide range of diameters.

**Single Barrel** standard wall thickness capillaries are offered either with or without inner filaments for quick filling in a variety of lengths and diameters. Two usable electrodes can be made from one 6-inch length. Borosilicate glass is Corning N51A.

**Thin Wall** single barrel capillaries are offered both with or without inner filaments. The concentricity of this material provides excellent strength. Micropipettes made from thin wall capillaries have fine tips with a short taper.

**Note:** Because electrode tips erode when left filled with saline solutions for long periods, electrodes should be made and filled immediately prior to use.

## Single-Barrel Standard Borosilicate Glass Tubing

Length	OD (mm)	ID (mm)	Filament	Fire-Polished	Quantity	Item	Price
3 in. (76 mm)	1.0	0.58	✓		500	<b>1B100F-3</b>	US\$54
3 in. (76 mm)	1.0	0.58			500	<b>1B100-3</b>	US\$54
3 in. (76 mm)	1.2	0.68	✓		350	<b>1B120F-3</b>	US\$54
3 in. (76 mm)	1.2	0.68			350	<b>1B120-3</b>	US\$54
3 in. (76 mm)	1.5	0.84	✓		225	<b>1B150F-3</b>	US\$54
3 in. (76 mm)	1.5	0.84		✓	300	<b>1B150-3</b>	US\$54
4 in. (100 mm)	1.0	0.58	✓	✓	500	<b>1B100F-4</b>	US\$59
4 in. (100 mm)	1.0	0.58		✓	500	<b>1B100-4</b>	US\$59
4 in. (100 mm)	1.2	0.68	✓	✓	400	<b>1B120F-4</b>	US\$59
4 in. (100 mm)	1.2	0.68		✓	350	<b>1B120-4</b>	US\$59
4 in. (100 mm)	1.5	0.84	✓	✓	300	<b>1B150F-4</b>	US\$59
4 in. (100 mm)	1.5	0.84		✓	300	<b>1B150-4</b>	US\$59
4 in. (100 mm)	2.0	1.12	✓		125	<b>1B200F-4</b>	US\$59
4 in. (100 mm)	2.0	1.12		✓	200	<b>1B200-4</b>	US\$59
6 in. (152 mm)	1.0	0.58	✓		500	<b>1B100F-6</b>	US\$71
6 in. (152 mm)	1.0	0.58			500	<b>1B100-6</b>	US\$71
6 in. (152 mm)	1.2	0.68	✓		350	<b>1B120F-6</b>	US\$71
6 in. (152 mm)	1.2	0.68			350	<b>1B120-6</b>	US\$71
6 in. (152 mm)	1.5	0.84	✓		225	<b>1B150F-6</b>	US\$71
6 in. (152 mm)	1.5	0.84			225	<b>1B150-6</b>	US\$71
6 in. (152 mm)	2.0	1.12	✓		125	<b>1B200F-6</b>	US\$71
6 in. (152 mm)	2.0	1.12			125	<b>1B200-6</b>	US\$71

## Thin-Wall Single-Barrel Standard Borosilicate (Schott Duran) Glass Tubing

OD (mm)	ID (mm)	FIL	Fire-Polished	Length	Quantity	Item	Price
1.0	0.75	✓		3 in. (76 mm)	500	<b>TW100F-3</b>	US\$56
1.0	0.75			3 in. (76 mm)	500	<b>TW100-3</b>	US\$56
1.2	0.90	✓	✓	3 in. (76 mm)	400	<b>TW120F-3</b>	US\$56
1.2	0.90			3 in. (76 mm)	350	<b>TW120-3</b>	US\$56
1.5	1.12	✓		3 in. (76 mm)	225	<b>TW150F-3</b>	US\$56
1.5	1.12		✓	3 in. (76 mm)	300	<b>TW150-3</b>	US\$56
1.0	0.75	✓		4 in. (100 mm)	500	<b>TW100F-4</b>	US\$59
1.0	0.75		✓	4 in. (100 mm)	500	<b>TW100-4</b>	US\$59
1.2	0.90	✓		4 in. (100 mm)	350	<b>TW120F-4</b>	US\$59
1.2	0.90			4 in. (100 mm)	350	<b>TW120-4</b>	US\$59
1.5	1.12	✓		4 in. (100 mm)	225	<b>TW150F-4</b>	US\$59
1.5	1.12		✓	4 in. (100 mm)	300	<b>TW150-4</b>	US\$59
1.0	0.75	✓		6 in. (152 mm)	500	<b>TW100F-6</b>	US\$71
1.0	0.75		✓	6 in. (152 mm)	500	<b>TW100-6</b>	US\$71
1.2	0.90	✓	✓	6 in. (152 mm)	400	<b>TW120F-6</b>	US\$71
1.2	0.90			6 in. (152 mm)	350	<b>TW120-6</b>	US\$71
1.5	1.12	✓		6 in. (152 mm)	225	<b>TW150F-6</b>	US\$71
1.5	1.12		✓	6 in. (152 mm)	300	<b>TW150-6</b>	US\$71

Prices shown are in U.S. dollars. Actual charges will vary because of import duty, freight, and currency fluctuations. To obtain an exact quotation, contact your WPI office.

GLASS, HOLDERS & ELECTRODES

# Patch Clamp Capillary Glass

To select the best patch clamp glass for your experiments, we have evaluated available glass types in terms of the four properties most crucial to successful patch clamp studies:

The **softening temperature** determines how easily each glass type can be pulled to the desired shape and the extent to which it can be heat polished. Glass with a high softening temperature is difficult to pull and causes unnecessary wear on the heating element of the puller. This makes it very hard to make electrodes that are reproducible and of consistent quality. Patch clamp glass with a low softening temperature is preferred; however, higher softening temperature glass is stronger.

**Electrical properties** determine how much noise the glass is likely to produce in recording situations. The lower the product of dielectric constant times the loss factor, the smaller the equivalent noise current the glass will produce (Rae and Levis, *Methods in Enzymology*, 207, p67, 1992). Patch clamp glass with good electrical properties is critical especially in single-channel recording.

**Sealability:** It is not clear what factors determine the sealing ability of the patch to the glass. Almost any glass can form a gigohm seal under the right conditions. Different glass types vary, however, in how easily they form a seal. It is important to select a patch clamp glass that seals easily. Good fire polish is critical for seal (see **DMF1000**).

**Leachable components:** Substances leached from glass can alter channel behavior. Since different channels are sensitive to different glass components, it is best to record one type of channel with several different kinds of pipette glass to eliminate any artifact due to the glass.

WPI offers capillary tubing made from two glass

types widely used in constructing patch clamp electrodes. The significant characteristics of each are as follows:

**PG52151-4**, **PG52152-4** and **PG52165-4** are prepared from Schott #8250 glass (equivalent to Corning #7052), one of the most widely used patch clamping glasses. This is a specially formulated borosilicate glass with a softening temperature that is 110°C lower than regular borosilicate glass (Corning 7740, or Pyrex). It has excellent sealing properties for most cells. Electrical properties are also very good.

**PG10150-4** and **PG10165-4** are composed of Corning #0010 glass, a high lead content (22% PbO) glass. Its thermal and electrical performance is between the Schott #8250 and Corning #8161 glasses described above. It is much more economical than Corning #8161 glass. It has been found that this glass causes much less alteration in channel behavior than Corning #8161 and Schott #8250 glass (Furman and Tanaka, *Biophys. J.* 53, p287, 1988).

*Patch clamp capillaries do not have microfilaments.*



## PATCH CLAMP CAPILLARY GLASS

Catalog#	Glass Type	OD/ID (mm)	Dielectric Constant	Softening Point °C	Quantity	Price
<b>PG52151-4</b>	#8250	1.5/1.0	4.9	720°	100	<b>US\$56</b>
<b>PG52165-4</b>	#8250	1.65/1.1	4.9	720°	100	<b>US\$56</b>
<b>PG10150-4</b>	#0010	1.5/0.75	6.7	625°	100	<b>US\$56</b>
<b>PG10165-4</b>	#0010	1.65/1.1	6.7	625°	100	<b>US\$56</b>

## Glass Handling Forceps

Ever had difficulty picking up a glass capillary? Special tips on these forceps solve the problem, holding glass firmly without risk of breakage. They also keep the glass clean and avoid contamination from skin oils.



**77020** Glass Handling Forceps **US\$47**

Prices shown are in U.S. dollars. Actual charges will vary because of import duty, freight, and currency fluctuations. To obtain an exact quotation, contact your WPI office.

World Precision Instruments • Tel: 941-371-1003 • Fax: 941-377-5428 • E-mail: sales@wpiinc.com • Internet: www.wpiinc.com

# Multi-Barrel Glass Capillaries

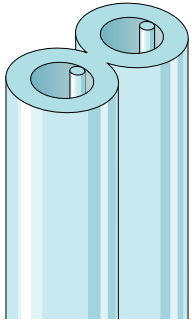

Two-Barrel

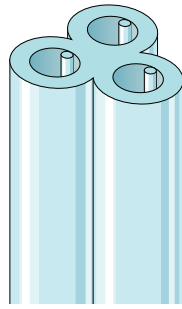

Three-Barrel

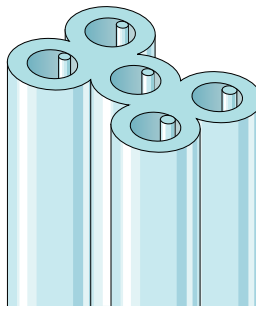

Five-Barrel

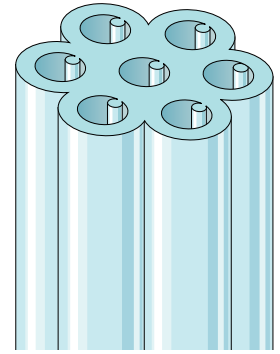

Seven-Barrel

**Multi-barrel** configurations are designed especially for microiontophoresis. Because the capillaries are fused together during manufacture, you will not need to twist them while pulling to seal the tips together. An inner filament in each barrel makes filling easy and fast.

**Also see PolyFil for a novel way to connect multi-barrel pipettes**

## Multi-Barrel Borosilicate Glass Tubing with Filaments

Length	Description	OD/ID (mm)	Filament	Quantity	Item	Price
4 in. (102 mm)	Two-Barrel	1.5/0.84	✓	100	<b>2B150F-4</b>	US\$65
4 in. (102 mm)	Three-Barrel	1.2/0.68	✓	100	<b>3B120F-4</b>	US\$65
4 in. (102 mm)	Five-Barrel	1.2/0.68	✓	65	<b>5B120F-4</b>	US\$65
4 in. (102 mm)	Seven-Barrel	1.2/0.58	✓	60	<b>7B100F-4</b>	US\$90
4 in. (102 mm)	Seven-Barrel	1.2/0.68	✓	75	<b>7B120F-4</b>	US\$90
6 in. (152 mm)	Two-Barrel	1.5/0.84	✓	100	<b>2B150F-6</b>	US\$77
6 in. (152 mm)	Three-Barrel	1.2/0.68	✓	100	<b>3B120F-6</b>	US\$77
6 in. (152 mm)	Five-Barrel	1.2/0.68	✓	65	<b>5B120F-6</b>	US\$74
6 in. (152 mm)	Seven-Barrel	1.0/0.58	✓	60	<b>7B100F-6</b>	US\$90

## Special Configuration Borosilicate Capillaries

**Septum Theta** offers superior cell impalement. The natural bevel resulting from the prominent spear-like projection of the septum gives microelectrodes a sharp, spear-point tip. This style has low resistance for use as a single microelectrode, and it can be used to make superior double-tipped microelectrodes with low trans-tip coupling. The natural bevel of Septum Theta also significantly increases the effective tip cross-section. As supplied, the width of the septum is approximately 0.2 mm; wall thickness is approximately 0.2 mm.

**Piggyback** glass consists of a pair of borosilicate capillaries fused together during manufacture. One barrel is larger than the other, and both have inner filaments for quick filling. Piggyback glass makes it simple to fabricate two-barrel electrodes with a significant tip diameter differential.

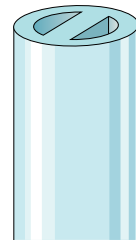

Septum Theta

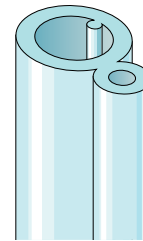

Piggyback

## Special Configuration Borosilicate Glass Tubing

Description	OD/ID (mm)	Length	Quantity	Item	Price
Septum Theta	1.5/1.02	6 in. (152 mm)	100	<b>TST150-6</b>	US\$90
Piggyback	1.51/0.84 0.75/0.35	4 in. (102 mm)	50	<b>PB150F-4</b>	US\$65
Piggyback	1.51/0.84 0.75/0.35	6 in. (152 mm)	50	<b>PB150F-6</b>	US\$96

## Borosilicate glass rod 1.0 mm diameter — for making tools, probes, tips

### Borosilicate Glass Rod

Description	OD (mm)	Length	Quantity	Item	Price
Glass Rod	1.0	4 in. (102 mm)	500	<b>GR100-4</b>	US\$55
Glass Rod	1.0	6 in. (152 mm)	500	<b>GR100-6</b>	US\$61

Prices shown are in U.S. dollars. Actual charges will vary because of import duty, freight, and currency fluctuations. To obtain an exact quotation, contact your WPI office.

GLASS, HOLDERS & ELECTRODES

# Five- and Seven-Barrel Micropipette Blanks

*High quality multi-barrel micropipette blanks for pressure injection*

The **P-5** and **P-7** micropipettes are designed for precise local application of chemicals in extracellular electrophysiological studies. Drug application may be by one of two methods:

1. microiontophoretic ejection of charged substances, or
2. pressure ejection.

**P-5** and **P-7** pipette blanks exhibit levels of quality and reproducibility impossible to match in handmade pipettes. They are compatible with most vertical pipette pullers that accommodate 3.00 mm diameter glass. P-5 and P-7 blanks have a solid ball pulling tip and are fabricated from 3.00 mm Kwik-Fil tubing. All barrels except the large central one have filaments.

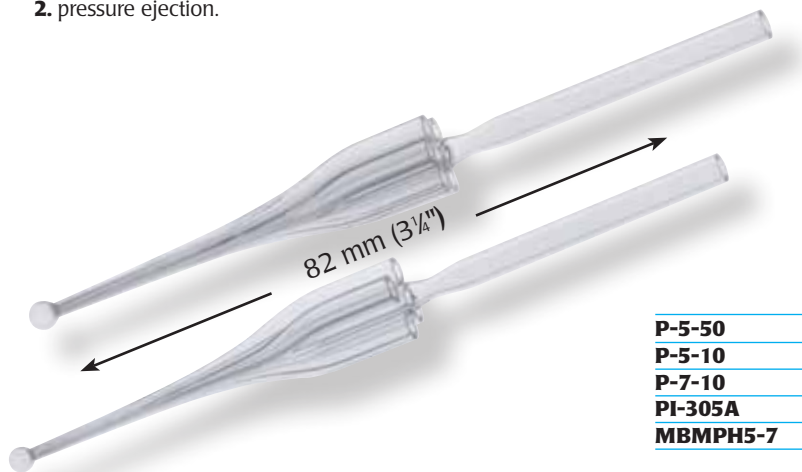

**See PMP-107 Programmable Multipipette Puller, Page 180.**

<b>P-5-50</b>	5-Barrel Micropipette Blank (pkg of 50)	US\$510
<b>P-5-10</b>	5-Barrel Micropipette Blank (pkg of 10)	US\$150
<b>P-7-10</b>	7-Barrel Micropipette Blank (pkg of 10)	US\$234
<b>PI-305A</b>	Pressure Ejection Kit (1 kit)	US\$114
<b>MBMPH5-7</b>	Holder for P-5 & P-7 Pipettes	US\$59



**PI-305A Pressure Ejection Kit** contains 20 plastic fittings, an insertion tool, five 5-ft lengths of colored tubing, a five-valve manifold coupling, six male luer adapters and one male/female luered line. These Pressure Ejection fittings connect the pressure ejection tubing to the **P-5** and **P-7** pipette barrels quickly and securely.

## Micropipette Storage Jar

Stores up to 30 micropipettes, filled or unfilled, up to three inches in length. A gentle sliding action inserts or removes pipettes without damage to the delicate tips.



<b>E210</b>	Storage Jar for 1.0 mm OD Micropipettes	US\$47
<b>E212</b>	Storage Jar for 1.2 mm OD Micropipettes	US\$47
<b>E215</b>	Storage Jar for 1.5 mm OD Micropipettes	US\$47
<b>E220</b>	Storage Jar for 2.0 mm OD Micropipettes	US\$47

### REPLACEMENT PARTS

<b>1965</b>	Foam Ring for 0.75 - 1.0 mm glass	US\$18
<b>1966</b>	Foam Ring for 1.2 - 1.5 mm glass	US\$18
<b>1967</b>	Foam Ring for 2.0 mm glass	US\$18

Prices shown are in U.S. dollars. Actual charges will vary because of import duty, freight, and currency fluctuations. To obtain an exact quotation, contact your WPI office.

World Precision Instruments • Tel: 941-371-1003 • Fax: 941-377-5428 • E-mail: sales@wpiinc.com • Internet: www.wpiinc.com

# $\mu$ Tip™ Borosilicate glass micropipettes

## Plain Shank or Luer Fittings



Eliminate the cost and trouble of making your own micropipettes — WPI can quickly supply your need for consistently sized pre-pulled glass micropipettes for injection of dyes or proteins into cells, oocytes and for many other biomedical laboratory applications. Tip diameters (ID) range from 0.1 to 10 micrometers.

- Schott Duran borosilicate glass
- 0.5 micrometer and smaller ID micropipettes include an internal glass fiber for easy filling
- Tip inner diameter tolerance  $\pm 20\%$
- Short taper yields high strength
- Nominal length  $\approx 50$  mm
- OD:ID = 1.33:1
- Standard capillary outer diameters are 1.0 mm (thin-wall) or 1.14 mm
- Every pipette individually tested and inspected
- Vacuum packed

## Silanized Tips (Luer Shank)

Silanization waterproofs the glass to retard water when inserting into cell. This will not let the outside fluid run down the pipette and get inside so easily.

## Micro Cannula

- 0.4mm O.D., 0.2mm I.D. tubing
- Autoclavable
- Biocompatible Perfluorocarbon tubing material

**KZ1101** Micro Cannula, 3-inch **US\$96**

Shank	Tip I.D.	Shank Length	Glass O.D.	Filament	Fire Polished	Catalog #	Price (pack of 10)
<b>PLAIN</b>	0.1 $\mu$ m	—	1.0 mm Thin-Wall	Yes	No	<b>TIP01TW1F</b>	<b>US\$143</b>
	0.2 $\mu$ m	—	1.0 mm Thin-Wall	Yes	No	<b>TIP02TW1F</b>	<b>US\$143</b>
	0.3 $\mu$ m	—	1.0 mm Thin-Wall	Yes	No	<b>TIP03TW1F</b>	<b>US\$143</b>
	0.4 $\mu$ m	—	1.0 mm Thin-Wall	Yes	No	<b>TIP04TW1F</b>	<b>US\$143</b>
	0.5 $\mu$ m	—	1.0 mm Thin-Wall	Yes	No	<b>TIP05TW1F</b>	<b>US\$143</b>
	1 $\mu$ m	—	1.0 mm Thin-Wall	No	Yes	<b>TIP1TW1</b>	<b>US\$143</b>
	2 $\mu$ m	—	1.0 mm Thin-Wall	No	Yes	<b>TIP2TW1</b>	<b>US\$143</b>
	5 $\mu$ m	—	1.0 mm Thin-Wall	No	Yes	<b>TIP5TW1</b>	<b>US\$143</b>
	10 $\mu$ m	—	1.0 mm Thin-Wall	No	Yes	<b>TIP10TW1</b>	<b>US\$143</b>
	10 $\mu$ m	—	1.14 mm A203XV glass *	No	Yes	<b>TIP10XV119</b>	<b>US\$155</b>
30 $\mu$ m	—	1.0 mm Thin-Wall	No	Yes	<b>TIP30TW1</b>	<b>US\$143</b>	
<b>LUER</b>	0.1 $\mu$ m	—	1.0 mm Thin-Wall	Yes	—	<b>TIP01TW1F-L</b>	<b>US\$143</b>
	0.2 $\mu$ m	—	1.0 mm Thin-Wall	Yes	—	<b>TIP02TW1F-L</b>	<b>US\$143</b>
	0.3 $\mu$ m	—	1.0 mm Thin-Wall	Yes	—	<b>TIP03TW1F-L</b>	<b>US\$143</b>
	0.4 $\mu$ m	—	1.0 mm Thin-Wall	Yes	—	<b>TIP04TW1F-L</b>	<b>US\$143</b>
	0.5 $\mu$ m	—	1.0 mm Thin-Wall	Yes	—	<b>TIP05TW1F-L</b>	<b>US\$143</b>
	1 $\mu$ m	—	1.0 mm Thin-Wall	No	—	<b>TIP1TW1-L</b>	<b>US\$143</b>
	2 $\mu$ m	—	1.0 mm Thin-Wall	No	—	<b>TIP2TW1-L</b>	<b>US\$143</b>
	5 $\mu$ m	—	1.0 mm Thin-Wall	No	—	<b>TIP5TW1-L</b>	<b>US\$143</b>
	10 $\mu$ m	—	1.0 mm Thin-Wall	No	—	<b>TIP10TW1-L</b>	<b>US\$143</b>
	30 $\mu$ m	—	1.0 mm Thin-Wall	No	—	<b>TIP30TW1-L</b>	<b>US\$143</b>
<b>LUER/SILANIZED</b>	5 $\mu$ m	1 inch	1.0 mm Thin-Wall	No	—	<b>TIP5TW1LS01</b>	<b>US\$143</b>
	5 $\mu$ m	2 inch	1.0 mm Thin-Wall	No	—	<b>TIP5TW1LS02</b>	<b>US\$143</b>
	10 $\mu$ m	1 inch	1.0 mm Thin-Wall	No	—	<b>TIP10TW1LS01</b>	<b>US\$143</b>
	10 $\mu$ m	2 inch	1.0 mm Thin-Wall	No	—	<b>TIP10TW1LS02</b>	<b>US\$143</b>
	30 $\mu$ m	1 inch	1.0 mm Thin-Wall	No	—	<b>TIP30TW1LS01</b>	<b>US\$143</b>
	30 $\mu$ m	2 inch	1.0 mm Thin-Wall	No	—	<b>TIP30TW1LS02</b>	<b>US\$143</b>

\* 10  $\mu$  (ID), 1.14 mm capillary pipettes are for use in WPI's **Nanoliter 2000**.

## $\mu$ TIP SAMPLER ASSORTMENTS

<b>TIPMIX01-05</b>	Two each, 0.1, 0.2, 0.3, 0.4, 0.5 $\mu$ m ID, plain shank	<b>US\$143</b>
<b>TIPMIX05-10</b>	Two each, 0.5, 1, 2, 5, 10 $\mu$ m ID, plain shank	<b>US\$143</b>
<b>TIPMIX01-05-L</b>	Two each, 0.1, 0.2, 0.3, 0.4, 0.5 $\mu$ m ID, Luer	<b>US\$143</b>
<b>TIPMIX05-10-L</b>	Two each, 0.5, 1, 2, 5, 10 $\mu$ m ID, Luer	<b>US\$143</b>

This micro cannula is ideal for placement in the carotid or femoral artery of mice, rats, and other small animal blood vessels. It can be used with a pressure transducer (WPI's **BLPR2**) for blood pressure measurement, or in conjunction with a micro-syringe injection system (like WPI's **UMPIII** or **MMP** pumps). The incorporated standard female luer fitting makes connecting to existing experimental plumbing quick and easy. The cannula is provided with a contoured-tip stainless steel stylet (trocar) to facilitate placement using established techniques. A movable "shoulder" ring provides a tie-in point to prevent accidental removal. The cannula may be left in place for 2 hours or more, and with proper care and cleaning, may be re-used multiple times. Instructions for use included.

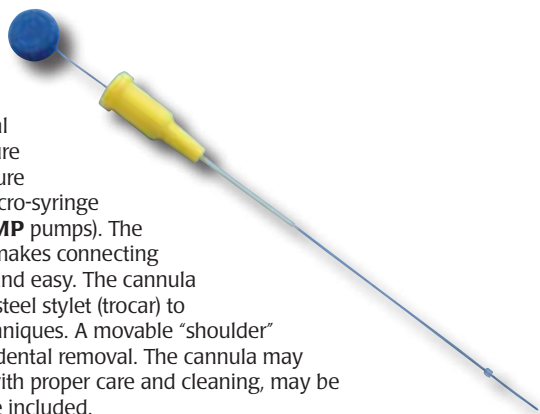

Prices shown are in U.S. dollars. Actual charges will vary because of import duty, freight, and currency fluctuations. To obtain an exact quotation, contact your WPI office.



# MicroFil™

**Nonmetallic  
syringe needle for  
filling micropipettes**

WPI's MicroFil™ fills micropipettes easily and reliably. Its long and fine tip allows you to start the filling very close to the pipette tip, eliminating both air bubble formation and clogging due to the washing down of dust particles. The transparent amber MicroFil needle is constructed from a combination of plastic and fused silica — no metal components are used. The MicroFil needle can be stored for days with the filling solution inside without clogging.

The MicroFil's tip elasticity is sturdy and very flexible though not unbreakable. Since it is more flexible than stainless steel needles, moderate bending will not block or damage the MicroFil needle. The combination of plastic and fused silica in the MicroFil tip is sturdier than plastic tips, allowing easy and repeated insertions into micropipettes. MicroFil's luer fitting allows easy coupling to syringes and syringe filters.

		1-5 pkgs	6-10 pkgs
<b>MF34G-5</b>	MicroFil, 34 ga., 67 mm long (pkg of 5)	US\$59	US\$49
<b>MF28G-5</b>	MicroFil, 28 ga., 97 mm long (pkg of 5)	US\$59	US\$49
<b>MF28G67-5</b>	MicroFil, 28 ga., 67 mm long (pkg of 5)	US\$59	US\$49

## CUSTOM MICROFIL

All MicroFil products, including custom orders, can be shipped immediately. Custom orders for special needs can be made using nine sizes of MicroFil tubing in lengths up to 50 cm — except for CMF90UxxL which has a maximum length of 10 cm because of its high resistance to flow. Quantity discounts available. **Specify length when ordering by inserting the length (in centimeter increments) into the catalog number in place of the XX's.**

<b>CMF20GxxL</b>	MicroFil, 20 Gauge, 700 µm ID, 850 µm OD (pkg of 4)	US\$143
<b>CMF22GxxL</b>	MicroFil, 22 Gauge, 530 µm ID, 700 µm OD (pkg of 4)	US\$143
<b>CMF23GxxL</b>	MicroFil, 23 Gauge, 530 µm ID, 665 µm OD (pkg of 4)	US\$143
<b>CMF26GxxL</b>	MicroFil, 26 Gauge, 320 µm ID, 430 µm OD (pkg of 4)	US\$143
<b>CMF28GxxL</b>	MicroFil, 28 Gauge, 250 µm ID, 350 µm OD (pkg of 4)	US\$143
<b>CMF31GxxL</b>	MicroFil, 31 Gauge, 100 µm ID, 238 µm OD (pkg of 4)	US\$143
<b>CMF34GxxL</b>	MicroFil, 34 Gauge, 100 µm ID, 164 µm OD (pkg of 4)	US\$143
<b>CMF35GxxL</b>	MicroFil, 35 Gauge, 75 µm ID, 144 µm OD (pkg of 4)	US\$143
<b>CMF90UxxL</b>	MicroFil, approx. 36 Gauge, 20 µm ID, 90 µm OD (pkg of 4)	US\$143

# PolyFil™

## Multi-barrel micropipette coupling kit

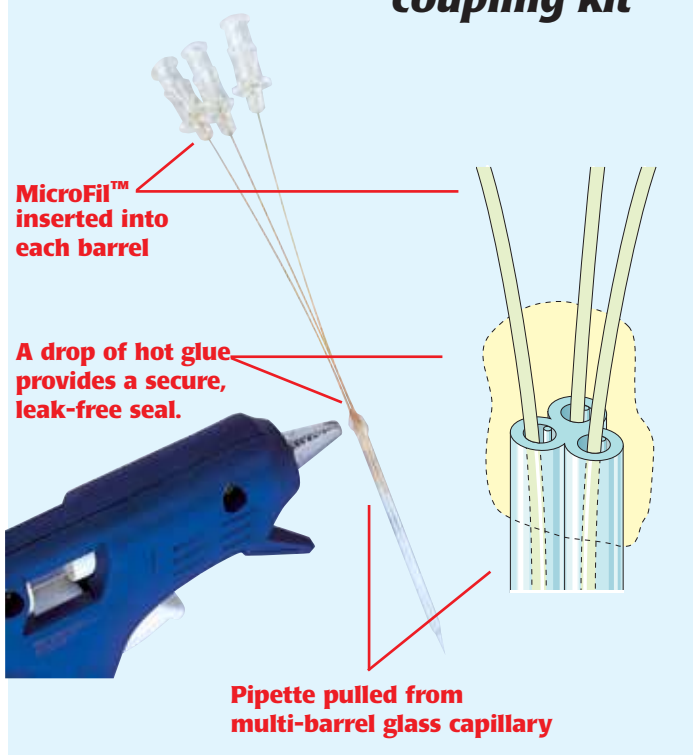

PolyFil allows easy and secure coupling of a multi-barrel micropipette to a pressure source. Coupling is achieved by bonding temperature-resistant and flexible MicroFil to the capillary tube with hot melt adhesive. The luer end of each MicroFil is connected to PVC tubing (200 PSI rated). Kits also include a five-port manifold that allows use of a single PV800 Series PicoPump to drive up to six micropipette barrels independently by switching on only the barrels to be injected. All connections are locking luers — pressure safe and convenient.

**Kit includes:** 1 pipette holder/handle, plastic; 7 pieces MF28G MicroFil; 7-pieces tubing with male luer lock fittings; 1 flow-thru manifold with five luer lock ports; 1 hot melt glue gun (110V only); 3 glue sticks.

<b>5440</b>	PolyFil Multi-Barrel Micropipette Coupling Kit	US\$210
<b>13316</b>	Mini Glue Gun and (3) glue sticks	US\$20

# Micropipette Holders & Half-Cells

WPI's microelectrode holder-half-cells couple fluid-filled glass micropipettes to high input impedance amplifiers. A Ag/AgCl pellet (or a silver wire) molded into the holder body provides stable potential. Electrical connection is made via male 2 mm pins or female 2 mm sockets. The pipette may be mounted axially or at right angles to the holder. Pipettes are held with screw-caps or rubber gaskets (without caps). Filling WPI microelectrode holders with electrolytes containing chloride results in stable electrode potential. Suitable electrolytes include KCl, NaCl and CaCl<sub>2</sub>. Holders are supplied for standard WPI single capillary tubing of 1.0, 1.2, 1.5 and 2.0 mm outside diameters. (Call WPI regarding custom designs for other glass diameters.) The holder style you select will depend on your experimental application, space, and instrumentation.

## Hints for selecting and ordering micropipette holders

1. Determine the required electrical connection on the holder: for example, if you wish to connect the holder to a 2 mm pin you should select a holder equipped with a 2 mm jack. Most WPI probes require a holder equipped with a 2 mm jack.
2. Decide on the required alignment of the electrical connection: either in-line with the glass pipette, or at a right angle to it. Space considerations in your experimental setup and requirements imposed by other pieces of equipment typically determine which alignment is appropriate.
3. Determine if you want to hold the glass pipette by a rubber gasket (e.g., MEH1S) or a screw-cap (e.g., MEH3S). Rubber gaskets offer easier insertion and removal of glass pipettes whereas screw-caps provide more secure mounts for micropipettes.
4. Choose a holder with either a silver wire or a silver/silver chloride pellet for the metal/liquid coupling. Silver/silver chloride pellets provide a more stable low-noise baseline which is important for low-noise DC recording. Pellets require the glass pipette and holder to be free of air bubbles to achieve a good connection. Silver wire holders are durable and are easier to use when the holder is equipped with a pressure port because the fluid in the pipette does not have to be filled to the top of the pipette to achieve a good electrical connection.
5. Choose a holder equipped with a pressure port only when you want to pressure inject liquid from the pipette. Two types of ports are available: 2.0 mm O.D. and standard "syringe-style" luer. The luer port is often recommended because it makes assembly and disassembly much easier. Quick-connect luer fittings for four common sizes of tubing (1/16", 3/32", 1/8", 5/32" I.D.) are included with each luer-equipped holder.
6. Some non-WPI preamplifiers or headstages cannot be mounted on micromanipulators. In such cases, a holder equipped with a rod (e.g., MEH8) permits the holder to be conveniently mounted on a micromanipulator.
7. Finally, remember to specify the O.D. of the glass you will be using when you place your order.

MEH6RF/SF is designed primarily for use with the Model 900A Micropressure System; EHB1 for use in electrode beveling; and MEH3SW for microtitration of chloride with a silver wire as the electrode and a solution of silver nitrate filling the holder. MPH models do not contain Ag/AgCl half-cells and are used for pressure injection of substances through microelectrodes. PicoNozzle, used for pressure injection with PV800 Series PicoPumps, includes an MPH6S holder — which may also be used to couple a micropipette to a syringe. APEH models are also designed for use in pressurized injection procedures.

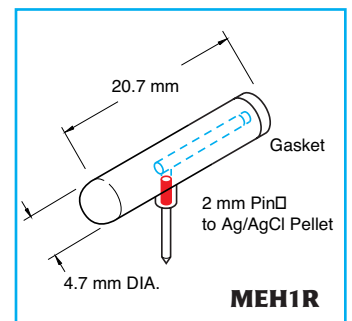
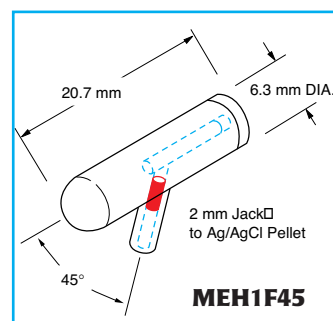
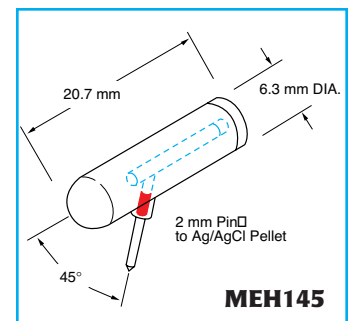
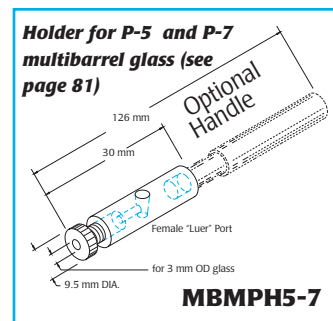
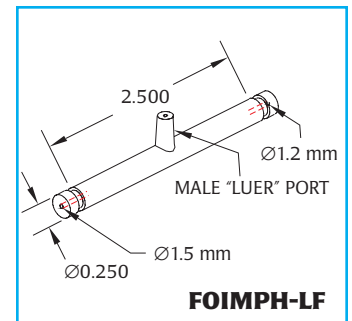
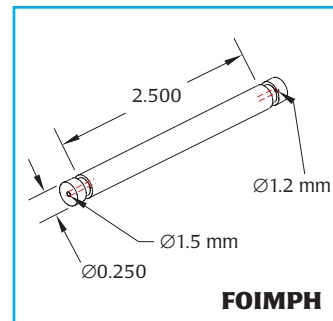
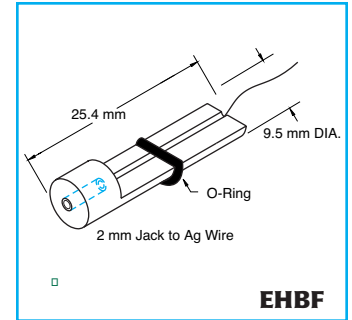
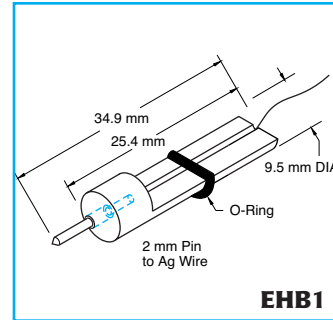
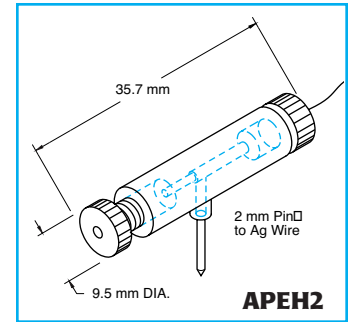
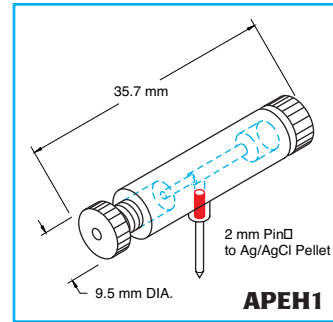

Prices shown are in U.S. dollars. Actual charges will vary because of import duty, freight, and currency fluctuations. To obtain an exact quotation, contact your WPI office.

## MICROELECTRODE HOLDERS

Order Number <i>Replace XX with glass diameter *</i>	Electric Connection Angle	Connector	Half-Cell	Pressure Port	Screw Cap	Designed for WPI Products	Price
<b>APEH1xx</b>	Right	Male	Pellet	No Port	2 Caps		US\$59
<b>APEH2xx</b>	Right	Male	Wire	No Port	2 Caps		US\$59
<b>EHB1xx</b>	Straight	Male	Wire	No Port	N/A	MBS, 48000	US\$59
<b>EHBfxx</b>	Straight	Female	Wire	No Port	N/A	MBS, 48000	US\$59
<b>FOIMPHxx</b>	Straight	Fiber Optic	None	No Port	w/Cap	MBS, 48000	US\$59
<b>FOIMPH-LFxx</b>	Straight	Fiber Optic	None	Male Luer	w/Cap	MBS, 48000	US\$59
<b>MBMPH5-7xx</b>	----	None	None	Female Luer	w/Cap		US\$59
<b>MEH145xx</b>	45°	Male	Pellet	No Port	No Cap		US\$59
<b>MEH1F45xx</b>	45°	Female	Pellet	No Port	No Cap	705, 773, 767, 721, FD223	US\$59
<b>MEH1Rxx</b>	Right	Male	Pellet	No Port	No Cap		US\$59
<b>MEH1RFxx</b>	Right	Female	Pellet	No Port	No Cap	705, 773, 767, 721, FD223	US\$59
<b>MEH1Sxx</b>	Straight	Male	Pellet	No Port	No Cap		US\$59
<b>MEH1SFxx</b>	Straight	Female	Pellet	No Port	No Cap	705, 773, 767, 721, FD223	US\$59
<b>MEH2Rxx</b>	Right	Male	Pellet	Male Luer	w/Cap		US\$59
<b>MEH2RFxx</b>	Right	Female	Pellet	Male Luer	w/Cap	705, 773, 767, 721, FD223	US\$59
<b>MEH2RFWxx</b>	Right	Female	Wire	Male Luer	w/Cap	705, 773, 767, 721, FD223	US\$59
<b>MEH2RWxx</b>	Right	Male	Wire	Male Luer	w/Cap		US\$59
<b>MEH2Sxx</b>	Straight	Male	Pellet	Male Luer	w/Cap		US\$59
<b>MEH2SFxx</b>	Straight	Female	Pellet	Male Luer	w/Cap	705, 773, 767, 721, FD223	US\$59
<b>MEH2SFWxx</b>	Straight	Female	Wire	Male Luer	w/Cap	705, 773, 767, 721, FD223	US\$59
<b>MEH2SWxx</b>	Straight	Male	Wire	Male Luer	w/Cap		US\$59
<b>MEH345xx</b>	45°	Male	Pellet	No Port	w/Cap		US\$59
<b>MEH3F45xx</b>	45°	Female	Pellet	No Port	w/Cap	705, 773, 767, 721, FD223	US\$59
<b>MEH3FW45xx</b>	45°	Female	Wire	Port	w/Cap		US\$59
<b>MEH3Rxx</b>	Right	Male	Pellet	No Port	w/Cap		US\$59
<b>MEH3RFxx</b>	Right	Female	Pellet	No Port	w/Cap	705, 773, 767, 721, FD223	US\$59
<b>MEH3RFWxx</b>	Right	Female	Wire	No Port	w/Cap	705, 773, 767, 721, FD223	US\$59
<b>MEH3RWxx</b>	Right	Male	Wire	No Port	w/Cap		US\$59
<b>MEH3Sxx</b>	Straight	Male	Pellet	No Port	w/Cap		US\$59
<b>MEH3SBxx</b>	Straight	Banana	Pellet	No Port	w/Cap	ISO-80, ISO-DAM8A	US\$59
<b>MEH3SBWxx</b>	Straight	Banana	Wire	No Port	w/Cap	ISO-80, ISO-DAM8A	US\$59
<b>MEH3SFxx</b>	Straight	Female	Pellet	No Port	w/Cap	705, 773, 767, 721, FD223	US\$59
<b>MEH3SFWxx</b>	Straight	Female	Wire	No Port	w/Cap	705, 773, 767, 721, FD223	US\$59
<b>MEH3SWxx</b>	Straight	Male	Wire	No Port	w/Cap		US\$59
<b>MEH3W45xx</b>	45°	Male	Wire	No Port	w/Cap	705, 773, 767, 721, FD223	US\$59
<b>MEH6RFxx</b>	Right	Female	Pellet	2.0-mm Port	w/Cap	705, 773, 767, 721, FD223	US\$59
<b>MEH6RFWxx</b>	Right	Female	Wire	2.0-mm Port	w/Cap	705, 773, 767, 721, FD223	US\$59
<b>MEH6SFxx</b>	Straight	Female	Pellet	2.0-mm Port	w/Cap	705, 773, 767, 721, FD223	US\$59
<b>MEH6SFWxx</b>	Straight	Female	Wire	2.0-mm Port	w/Cap	705, 773, 767, 721, FD223	US\$59
<b>MEH7xx</b>	Right	Male	Pellet	2.0-mm Port	w/Cap		US\$59
<b>MEH7Wxx</b>	Right	Male	Wire	2.0-mm Port	w/Cap		US\$59
<b>MEH8xx</b>	Right	Male	Pellet	No Port	w/Cap		US\$59
<b>MEH900Rxx</b>	Right	Male	Pellet	2.0-mm Port	w/Cap	900A	US\$59
<b>MEH900Sxx</b>	Straight	Male	Pellet	2.0-mm Port	w/Cap	900A	US\$59
<b>MPH1xx</b>	—	None	None	Female Luer	w/Cap		US\$59
<b>MPH3xx</b>	—	None	None	Male Luer	w/Cap		US\$59
<b>MPH4xx</b>	—	None	None	2.0-mm Port	w/Cap		US\$59
<b>MPH6Pxx</b>	Right	Male	Pellet	Female Luer	w/Cap	Piconozzle Kit (5430-XX)	US\$59
<b>MPH6Rxx</b>	Right	Male	Wire	Female Luer	w/Cap	Piconozzle Kit (5430-XX)	US\$59
<b>MPH6Sxx</b>	—	None	None	Female Luer	w/Cap	Piconozzle Kit (5430-XX)	US\$59

\* Specify O.D. of glass (1.0, 1.2, 1.5 or 2.0 mm) by replacing XX in the Order Number with 10, 12, 15 or 20.

### Handles and Accessories (not included)

Handle #2505 is for use with WPI manipulators. The smaller diameter handle #5444 is required for use with Narishige and Zeiss manipulators.

<b>2505</b>	1/4-in (6.3 mm) diameter handle	US\$17
<b>5444</b>	3/16-in (4.8 mm) diameter handle	US\$34
<b>GO1-100</b>	Replacement gasket 1.0 mm, Package of 100	US\$35
<b>GO2-100</b>	Replacement gasket 1.2 mm, Package of 100	US\$35
<b>GO3-100</b>	Replacement gasket 1.5 mm, Package of 100	US\$35
<b>GO4-100</b>	Replacement gasket 2.0 mm, Package of 100	US\$35
<b>1571</b>	Clear Silicone Rubber Sealant (-4.7 oz-)	US\$35

Prices shown are in U.S. dollars. Actual charges will vary because of import duty, freight, and currency fluctuations. To obtain an exact quotation, contact your WPI office.

World Precision Instruments • Tel: 941-371-1003 • Fax: 941-377-5428 • E-mail: sales@wpiinc.com • Internet: www.wpiinc.com

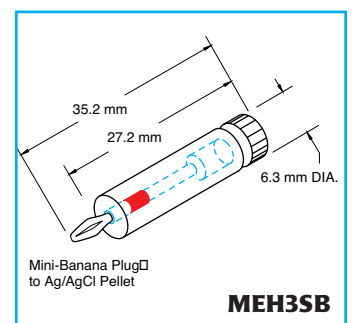
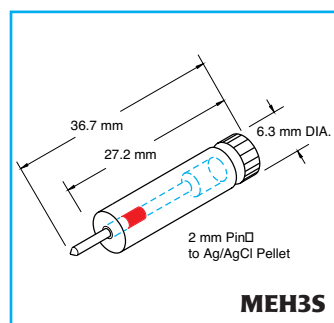
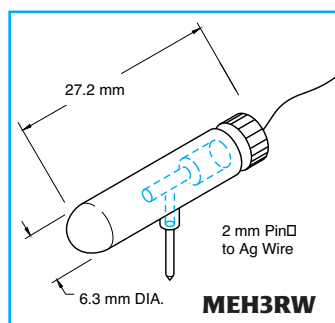
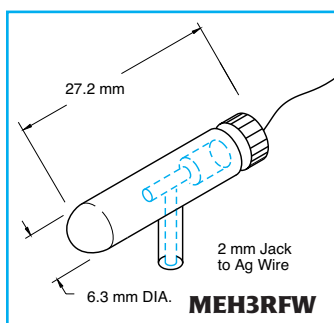
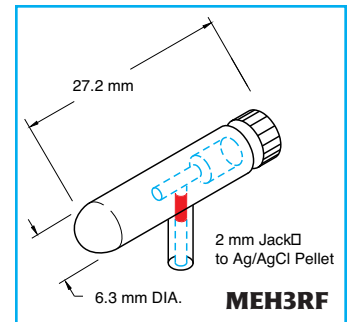
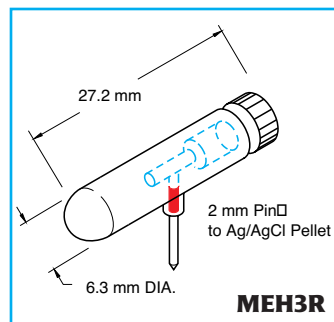
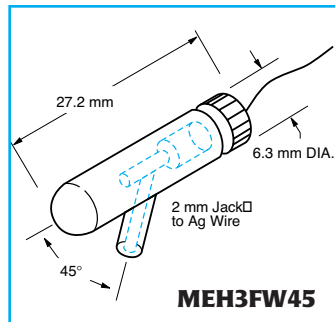
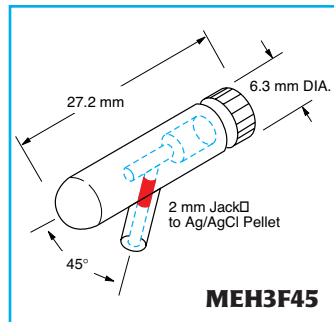
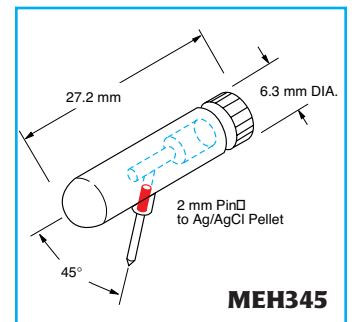
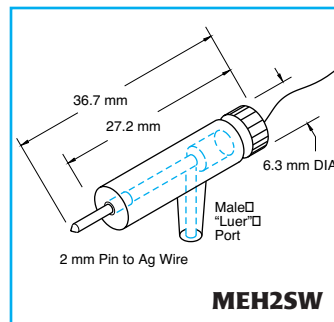
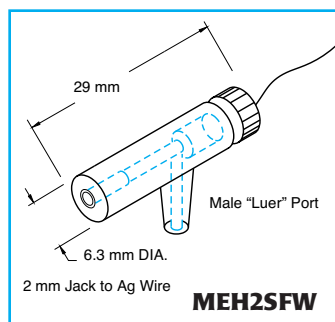
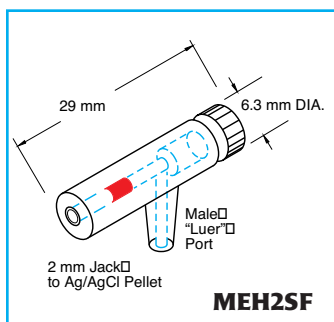
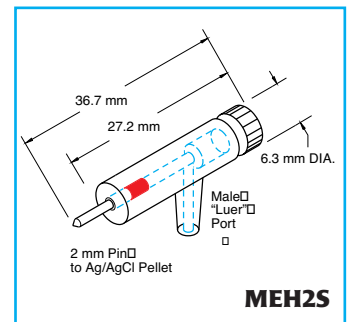
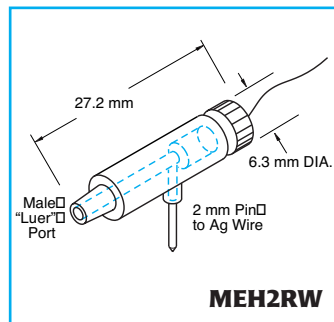
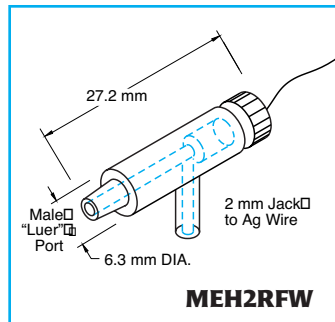
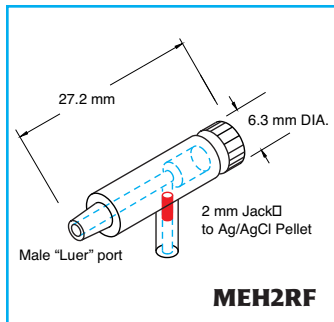
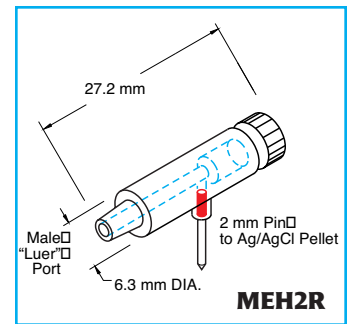
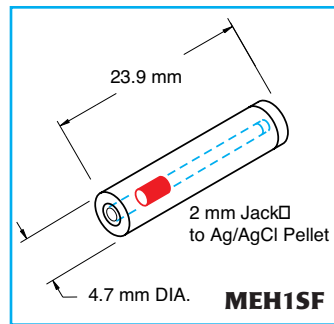
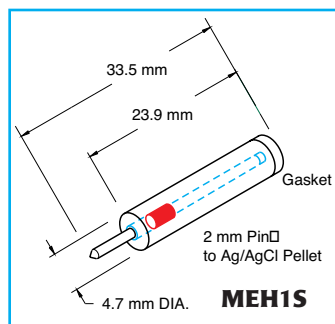
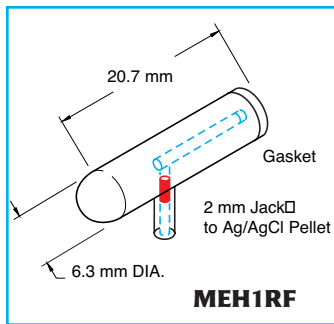

Prices shown are in U.S. dollars. Actual charges will vary because of import duty, freight, and currency fluctuations. To obtain an exact quotation, contact your WPI office.

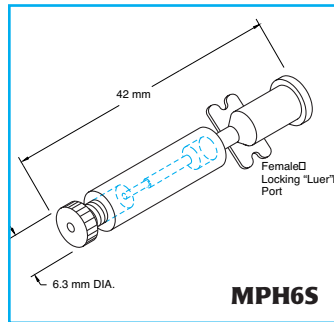
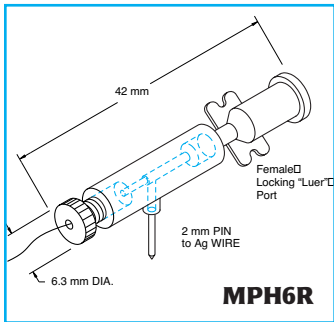
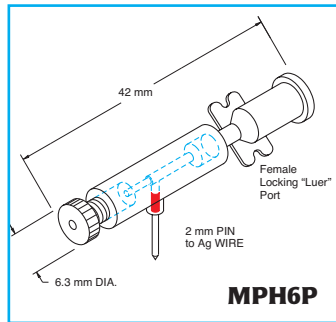
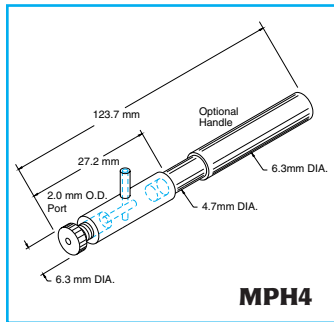
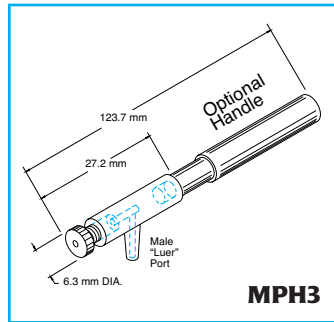
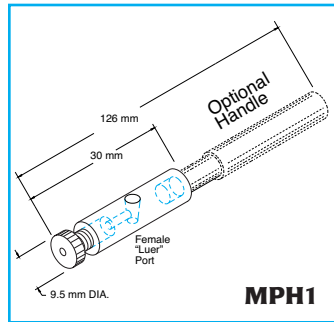
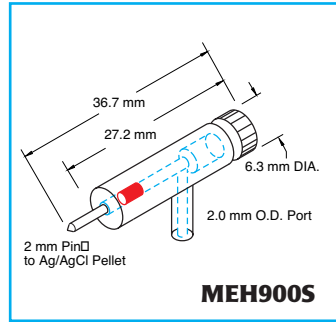
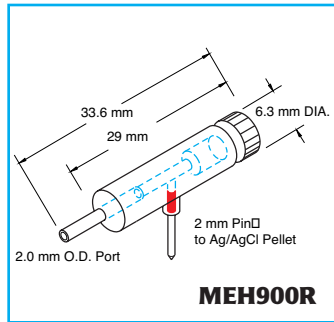
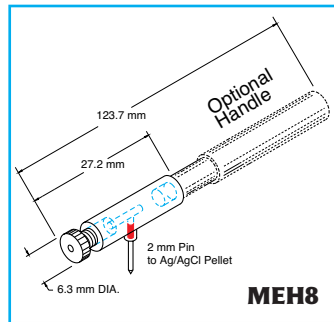
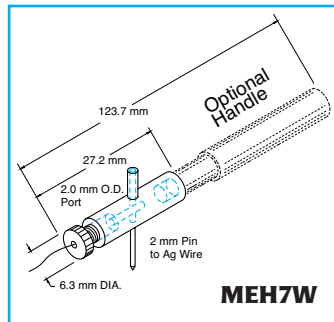
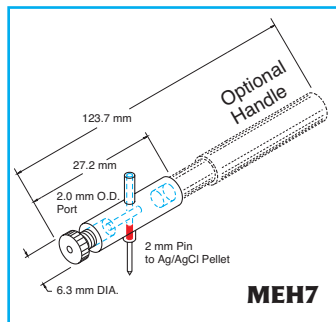
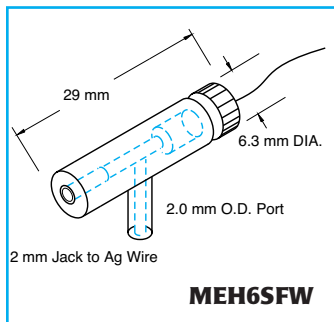
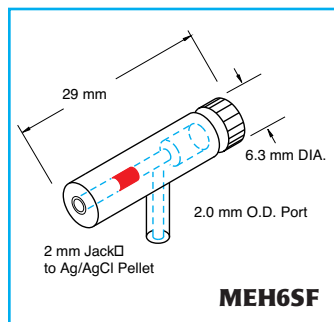
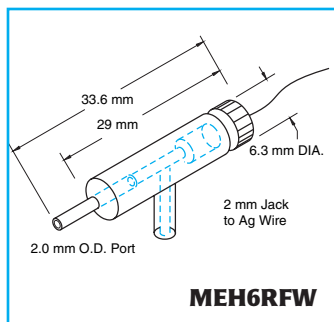
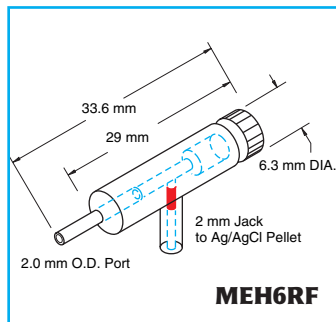
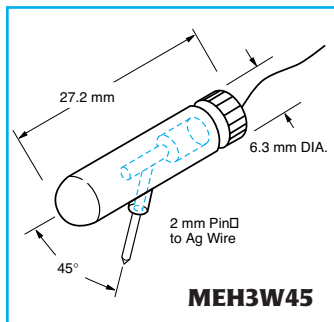
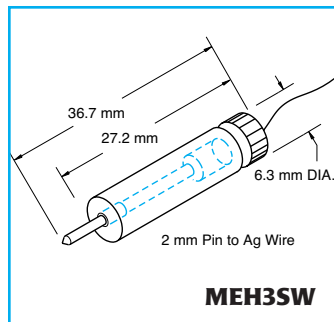
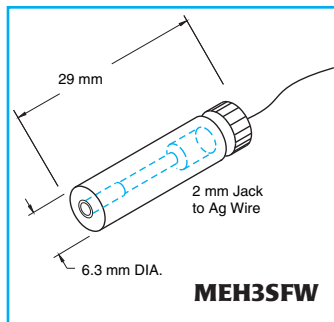
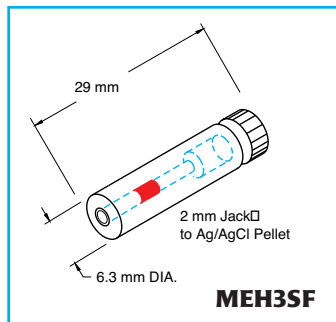
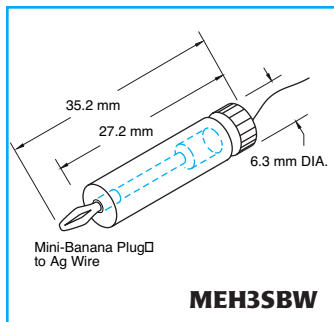

Prices shown are in U.S. dollars. Actual charges will vary because of import duty, freight, and currency fluctuations. To obtain an exact quotation, contact your WPI office.

World Precision Instruments • Tel: 941-371-1003 • Fax: 941-377-5428 • E-mail: sales@wpiinc.com • Internet: www.wpiinc.com

# BetterSkin™ Electrodes

**DIN socket  
now available!**

- **WPI's unique Ag/AgCl pellet manufacturing process gives increased mechanical strength for extra durability**
- **Highly porous surface for low impedance, high current passing capability and stable, low noise measurements**
- **High flex cable comes in shielded and unshielded form (Carbon fiber cable for NMR environment is available upon request)**
- **Strong epoxy house increases durability and makes cleaning easy**
- **Ultra-high purity material for low offset and drift**



WPI's new BetterSkin™ electrodes are high quality Ag/AgCl reusable surface-mounted electrodes designed to be used for the acquisition of all biopotentials. Each electrode is fabricated using an optimum quality sintered Ag/AgCl pellet encased within a strong epoxy housing designed to have an extended lifetime. The result is a superior electrode that provides accurate and clear transmission of even the smallest surface biopotentials. In comparison to standard "stamped" metal electrodes and Ag/AgCl disposable electrodes, WPI's BetterSkin electrodes provide increased stability, lower noise and lower offset voltage during surface biopotential recording. These features are particularly important during measurement of very small potential signals, such as EMG or EEG recording.

Four BetterSkin electrode sizes are currently offered: 7-mm, 13-mm, 16-mm and 19-mm (OD). The 7-mm electrodes are designed for use where close spacing between biopotential recording sites is required. The medium

sized electrodes (13-16 mm OD) are general purpose electrodes and appropriate for most applications. The 19-mm large size electrodes are designed for optimal surface skin contact for use during long-term biopotential recording.

Three different connector and cable combinations are offered: a 2-mm pin with 1 meter unshielded cable; a 2-mm pin with 1

meter shielded cable (shielding is connected to an additional 2 mm grounding pin); and 1.5 mm DIN safety socket with 1 meter unshielded cable. All electrodes require adhesive disks (e.g., WPI's **ADD200** series) and recording gel (**GEL100**).

Bulk discount orders are possible and trade-inquiries are also welcome.

## Skin Electrodes with 2 mm Gel Capacity and 1 m Lead

	OD	Sensor Diam.	Housing Height	Pin Diam.	Shield	Ground Pin Diam.	DIN Socket	Electrode Price	Discs
									Adhesive Disc (pkg of 100) Disc Price
<b>EL204</b>	7 mm	4 mm	5 mm	2 mm	—	—	—	—	<b>ADD204</b>
<b>EL204S</b>	7 mm	4 mm	5 mm	2 mm	Yes	2 mm	—	—	<b>ADD204</b>
<b>EL204D</b>	7 mm	4 mm	5 mm	—	—	—	1.5 mm	—	<b>ADD204</b>
<b>EL208</b>	13 mm	8 mm	6 mm	2 mm	—	—	—	—	<b>ADD208</b>
<b>EL208WS</b>	16 mm	8 mm	6 mm	2 mm	Yes	2 mm	—	—	<b>ADD208</b>
<b>EL208D</b>	13 mm	8 mm	6 mm	—	—	—	1.5 mm	—	<b>ADD208</b>
<b>EL208WD</b>	16 mm	8 mm	6 mm	—	—	—	1.5 mm	—	<b>ADD208</b>
<b>EL212</b>	19 mm	12 mm	7 mm	2 mm	—	—	—	—	<b>ADD212</b>



## Conductive Electrode Gel

A very high quality non-irritating conductive multipurpose electrode gel for use with skin electrodes that are not pre-gelled. Ideal for use in EEG, ECG, and EMG applications.

Tube contains 8 oz. (250 g).

Shipping weight: 1 lb. (0.5 kg).

**GEL100** Conductive Electrode Gel

## Disposable Ag/AgCl Snap Electrodes

Disposable Ag-AgCl snap adhesive electrodes. Pre-gelled for simple peel and stick application. An ideal resting ECG electrode. Size: 0.875 x 1.75 inches. (Electrode lead available separately.)

### Ag/AgCl PROBES & Ag/AgCl SNAP ELECTRODES

<b>EL203</b>	Disposable Snap Electrodes (package of 30)
<b>500131</b>	Snap Cable, 1m, 2mm pin (package of 5)
<b>500330</b>	Snap Cable, 7-lead, DIN (1.5 mm pin)

Prices shown are in U.S. dollars. Actual charges will vary because of import duty, freight, and currency fluctuations. To obtain an exact quotation, contact your WPI office.

# Ag/AgCl Half-Cells

New, improved sintered pellets with lower resistance and high strength. Stable and well balanced in the presence of current, these small and inexpensive half-cells are easy to work with as bath electrodes.

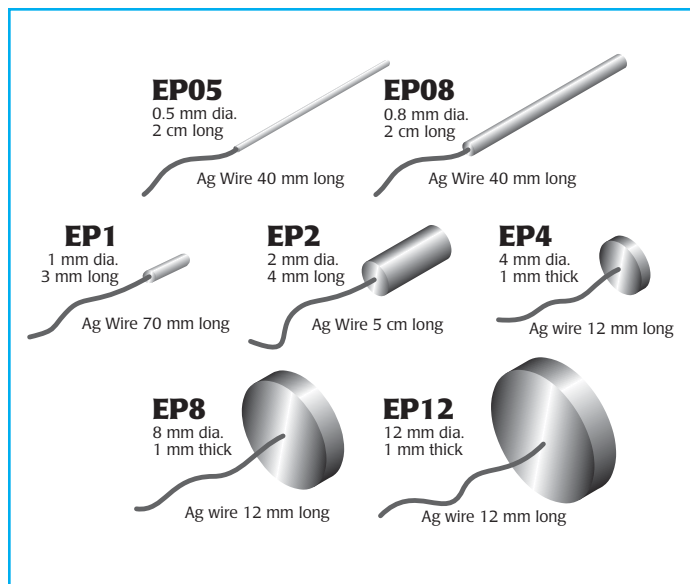

<b>RC1</b>	Reference Cell with 1.5 m lead
<b>RC1T</b>	Reference Cell, 1.5 m lead, 2 mm pin
<b>RC2</b>	Reference Cell with 2.0 mm pin
<b>RC2F</b>	Reference Cell with female connector
<b>RC3</b>	Reference Cell with epoxy body, 4.5 mm diam x 50 mm
<b>RC4</b>	Reference Cell with glass body, 4.0 mm diam x 75 mm
<b>RC5</b>	Reference Cell with glass body, 4.0 mm diam x 50 mm
<b>RC6</b>	Reference Cell with glass body, 1.5 mm diam x 50 mm
<b>EP05</b>	Ag/AgCl Electrode 0.5 mm diam x 20 mm
<b>EP08</b>	Ag/AgCl Electrode 0.8 mm diam x 20 mm
<b>EP1</b>	Ag/AgCl Electrode 1.0 mm diam x 2.5 mm
<b>EP2</b>	Ag/AgCl Electrode 2.0 mm diam x 4 mm
<b>EP4</b>	Ag/AgCl Electrode 4.0 mm diam x 1 mm
<b>EP8</b>	Ag/AgCl Electrode 8.0 mm diam x 1 mm
<b>EP12</b>	Ag/AgCl Electrode 12.0 mm diam x 1 mm
<b>3578</b>	Adapter Cable for Ag/AgCl Pellets

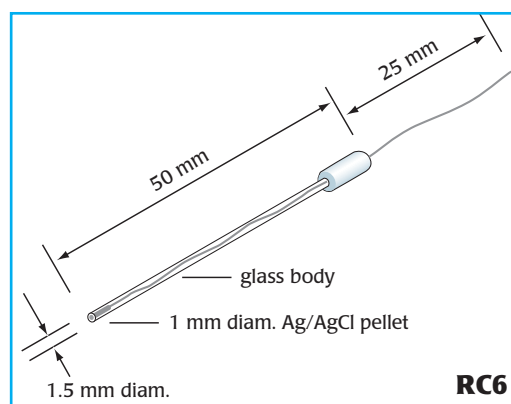
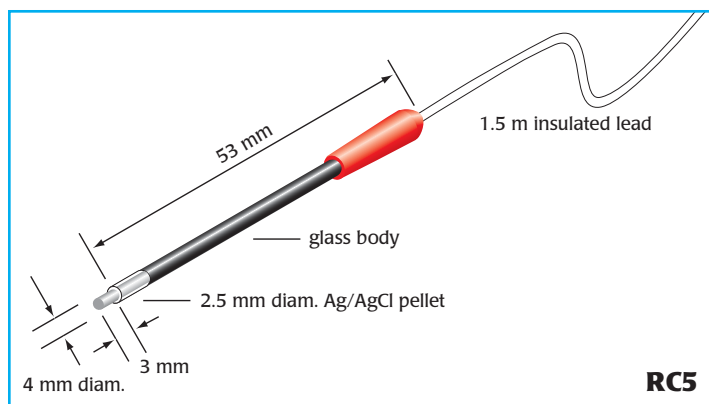
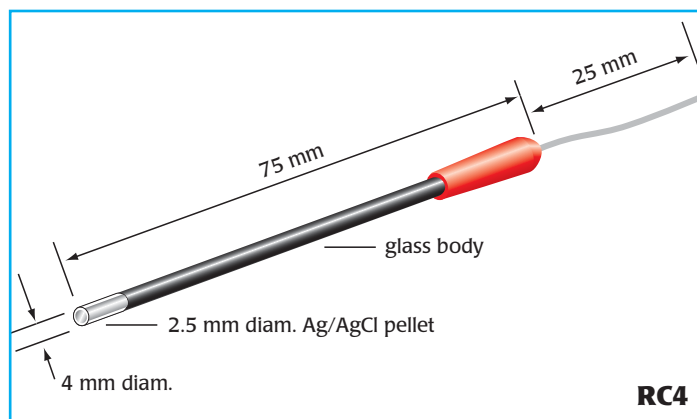
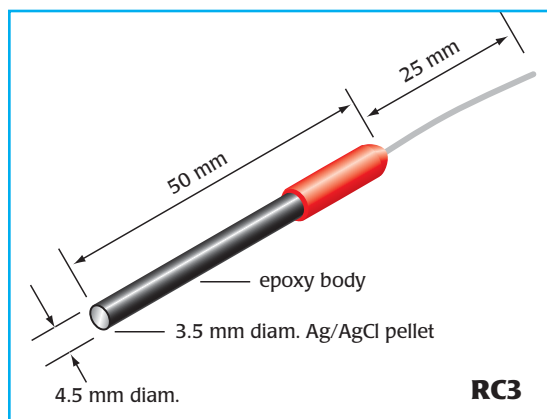
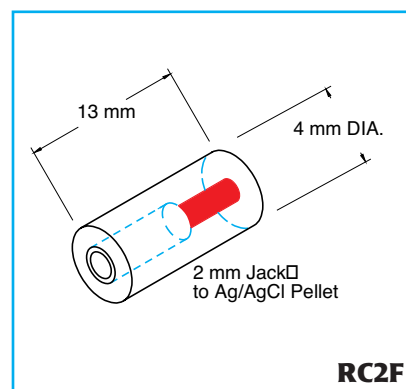
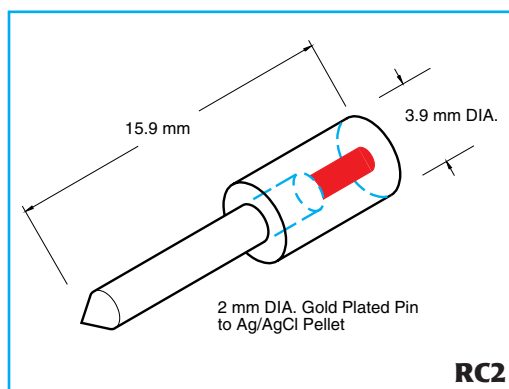
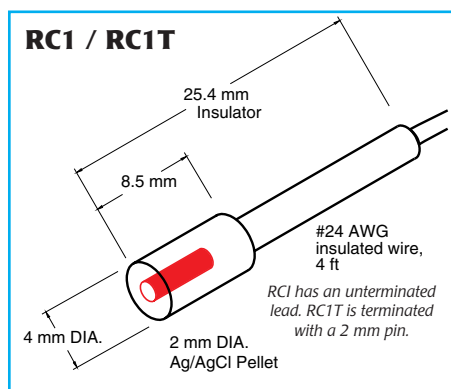

GLASS HOLDERS

ELECTRODES

Prices shown are in U.S. dollars. Actual charges will vary because of import duty, freight, and currency fluctuations. To obtain an exact quotation, contact your WPI office.

World Precision Instruments • Tel: 941-371-1003 • Fax: 941-377-5428 • E-mail: sales@wpiinc.com • Internet: www.wpiinc.com